

**Rear Vision System – Aftermarket and Factory 5.0”, 8.4” and 6.1” MyGig
Touch Screen Display
(Factory Display requires Chrysler/Dodge dealer to activate)
2009 – Current* Dodge Ram
(Kit part number 1009-6503)**

*NOTE: 2013 and newer Ram vehicles require raising Reverse signal voltage using a Single Pull Dual Throw Relay when used with aftermarket mirrors and displays. (Please refer to detailed installation steps on Page 7 of these instructions.)

**Please read thoroughly before starting installation
and check that kit contents are complete.**

Items Included in the Kit:

- Chassis Harness with RCA**
- Tailgate Handle with Camera
- 8.4”, 5.0” Factory Touch Screen Jumper Harness (2013 to present Ram option only)**
- 6.1” MyGig Factory display 22-pin camera input harness (2009 to 2012)*
- 1 bag containing:
 - Plug for Non-Locking Tailgates (Optional)
 - Red wire with terminal for older vehicles (optional)
 - Black wire with terminal for older vehicles (optional)
- 1 bag containing:
 - These instructions
 - Template

**In some cases a RCA extension may be required to connect to your aftermarket display; Kit# 9002-6111 may be purchased from Brandmotion.com

Tools Required:

- Socket Wrench with 7mm & 8mm Sockets
- T20 and T30 Torx Bits
- Phillips and Flat Blade Screwdrivers
- Power Drill
- 1/8” Drill Bit
- 1” Hole Cutter
- Pushpin Removal Tool
- Round File or Deburring Tool
- Center Punch
- Utility Knife or Side Cutters
- Masking Tape
- Corrosion Inhibitor (recommended)
- Soldering Iron & Solder (recommended)
- Wire Ties (recommended)

We strive to provide accurate and up-to-date installation instructions.

For the latest full color instructions, please visit www.brandmotion.com

Install Tailgate Handle Camera

1. Set up a work area on which to set the tailgate after removal. This area should be well protected to avoid damage to tailgate.
2. **For 2013 and newer Ram vehicles ONLY,** (older vehicles, please proceed to Step 3) use your fingers to remove the black plastic filler panel at rear of pickup bed adjacent to the license plate. Press on the end tab and lifting outward. Next, slide the red tab from the locked position and unplug the tailgate power lock harness connector.



- Unhook both tailgate support straps by inserting a Flat Blade Screwdriver between the locking tab and strap mount. Lift the locking tab away from the strap mount with the screwdriver while sliding the tailgate strap upwards. The tailgate strap hanger can now be removed from the mount.



- Open tailgate about ten degrees and lift right side of the tailgate off the pin. Next, slide tailgate to the right to remove taking care not to damage the paint. NOTE: Tailgate removal and installation requires two people.
- Remove the handle access panel inside the tailgate using a T30 Torx driver. (NOTE: If vehicle is equipped with a bed liner, the tailgate portion of the liner must be removed prior to this step.)



- Remove nuts attaching handle to tailgate using an 8mm Socket, then remove handle from tailgate. (NOTE: Non-power locking tailgate mechanism shown.)



INSTALLATION INSTRUCTIONS

- If equipped, remove the lock cylinder from existing handle.



- If equipped, remount the lock cylinder in the supplied Tailgate Camera Handle using a 8mm Socket and existing hardware.



Follow Steps 9 through 21 for 2013 and newer Ram vehicles ONLY:

- Use a Utility Knife or Side Cutters to remove the Rubber Grommet closest to the camera end from the Camera Harness. Wrap the Camera Harness with Electrical Tape where you removed the grommet.



- Route the gray Camera Harness connector and wiring through tailgate and install supplied handle using a 8mm Socket with the existing hardware.



- Reinstall handle bolts.
- Route the supplied Camera Harness through the pass-through hole in the inner brace of the tailgate.



- Route Camera Harness through the rectangular hole in the bottom of the tailgate.
- Use Masking Tape to affix supplied Template B above the oval spare tire access slot (located just right of center on the pickup bed rear edge) and mark the hole center using a Center Punch.



INSTALLATION INSTRUCTIONS

- Check the area behind the hole you marked for wiring. If any wiring is present, secure it away from the area to be drilled.
- Use a 1/8" drill bit to make a pilot hole at the center punch mark. Then use a 1" Hole Saw to make the Camera Harness pass through hole.

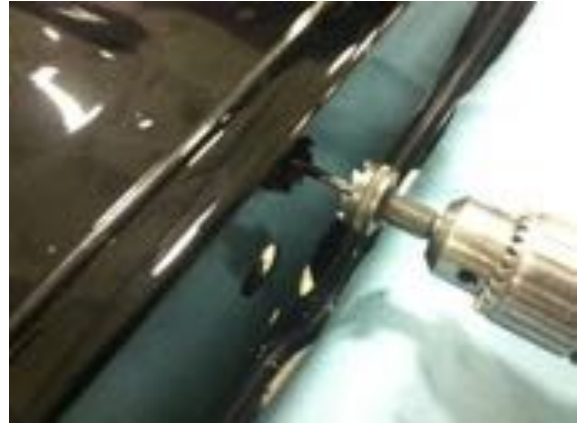

- RECOMMENDED:** Use a Cotton Swab or small brush to apply Corrosion Inhibitor to exposed edges.



- Taking care not to damage the Camera Harness, reinstall tailgate by lifting it into place, rotating it down about ten degrees, and sliding it to the left.
- Reinstall both tailgate straps by placing the large opening of the tailgate strap hangers over the tailgate strap mounts and pulling down. Proceed to Step 33.
- Seat the Camera Harness grommet in the pass through hole you drilled in the end of the pickup bed using your fingers.
- Plug in the tailgate power lock harness connector (removed in Step 2) and slide the red tab to the locked position. Reinstall the black plastic filler panel at rear of pickup bed adjacent to the license plate.

Follow Steps 22 through 32 for 2009 through 2012 Ram vehicles ONLY

22. Use a Utility Knife or Side Cutters to remove the Rubber grommet closest to the gray connector end from the Camera Harness. Wrap the Camera Harness with Electrical Tape where you removed the grommet.



23. Use Masking Tape to affix supplied Template A to tailgate. An existing small rectangular hole in the center of the lower tailgate edge will match up with the left side of Template A. Use a Center Punch to mark the tailgate at the "X" on Template A and remove Template A.

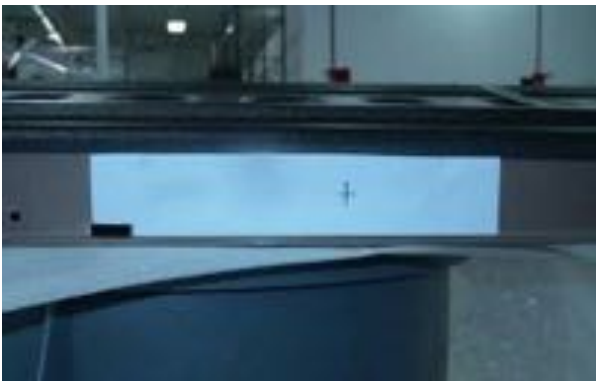

24. Use a 1/8" drill bit to make a pilot hole at the center punch mark. Then use a 1" Hole Cutter to cut a pass through in the tailgate.



INSTALLATION INSTRUCTIONS

25. Clean rough edges of the hole using a Deburring Tool or Round File. RECOMMENDED: Apply Corrosion Inhibitor to the metal edges.



26. Route the gray Camera Harness connector and wiring through tailgate and install supplied handle using an 8mm Socket with the existing hardware.



27. Reinstall handle bolts.
28. Route the supplied Camera Harness through the pass-through hole in the inner brace of the tailgate.



29. Seat Camera Harness grommet in the pass through hole you drilled in the tailgate using your fingers
30. Taking care not to damage the Camera Harness, reinstall tailgate by lifting it into place, rotating it down about ten degrees, and sliding it to the left.

31. Reinstall both tailgate straps by placing the large opening of the tailgate strap hangers over the tailgate strap mounts and pulling down.
32. Feed the gray end of the Camera Harness through the rectangular opening at the rear of the truck bed.



Install Chassis Harness

33. Remove front driver's side kick panel/sill plate by lifting it at the rear and working your way forward with your hands.



34. Remove rear driver's-side sill plate by lifting it at front and working your way back with your hands.



INSTALLATION INSTRUCTIONS

35. Lift driver's side rear seat to expose the under seat storage compartment. Pull three pushpins out of the driver's side rear seat storage compartment using a Pushpin Removal Tool.



36. Pull back carpeting and remove the body floor plug.



37. Insert the large gray connector end of the supplied Chassis Harness through the body floor plug hole.



38. Seat grommet affixed to the supplied Chassis Harness in the body floor plug hole by firmly pressing it with your fingers.



39. Route the Chassis Harness RCA connector through the seat riser reinforcement hole.



40. Reinstall carpet and reinstall the three pushpins removed earlier.
41. Route Chassis Harness around B-pillar trim by lifting up on the trim and feeding harness through to front.



INSTALLATION INSTRUCTIONS

42. Continue to route Chassis Harness along the driver's side front door opening sill area. NOTE: This will be a tight fit, as the supplied Chassis Harness will follow the existing wiring harness.



43. Reinstall rear sill plate by pressing it back into place with your hands.
44. Remove driver's side kick panel insulation pad retainers using a Pushpin Removal Tool. Route the supplied Chassis Harness behind the insulation (between insulation and metal frame) then reinstall the insulation).



45. Reinstall front kick panel/sill plate by pressing it back into place with your hands.
46. If needed, install aftermarket display/ Navigation display per manufacturer's instructions.

Connect Chassis Harness to Vehicle Wiring

47. Connect the supplied Chassis Harness Red, Green, and Black leads as directed in the chart appropriate for your vehicle below.

Chart A: 2013 to present Ram Equipped with Factory 8.4" Touch Screen

Color	Polarity	Function	Location
Green	(+)	Reverse	Splice both Green and Red leads to pink/yellow wire in Cavity 19 of black under dash Connector I310 M adjacent to parking brake grommet (Figures 1 & 2)
Red	(+)	Ignition	
Black	(-)	Ground	Chassis ground

Figure 1



Figure 2

Connector I 310 M (black)

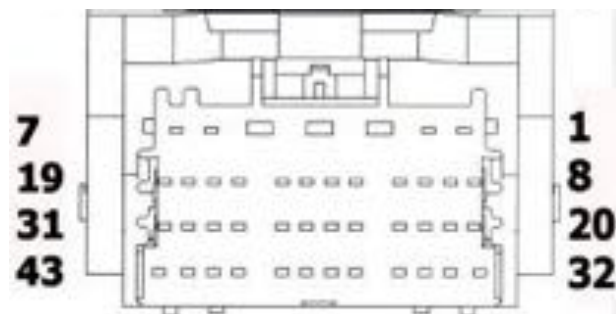

Chart B: 2013 to present Ram Aftermarket mirror/ display / Aftermarket NAV

Using a commonly available Single Pull Dual Throw Relay (Figure 3), splice the leads of the supplied Mirror Harness to each numbered circuit of the female relay connector as follows (Recommended: Solder and cover with Heat Shrink Tubing.):

Relay Connections

Circuit	Function/ Polarity	Connection
86	Reverse (+)	Splice Relay wire to white/tan wire in under dash BCM white 48-pin connector Pin 41 (Figure 4)
87	Ignition (12v +)	Splice Red (Ignition) Mirror Harness lead to Relay wire. Then splice Relay wire to pink/yellow wire in Cavity 19 of under dash black I310 F Connector adjacent to parking brake cable grommet (Figures 5 & 6)
85	Ground (-)	Splice Black (Ground) Mirror Harness lead to Relay. Then splice Relay wire to Chassis ground and attach to an existing ground bolt or use a nut to secure to an existing stud.
30	Reverse (+)	Splice Green (Reverse) wire of supplied Mirror Harness to Relay wire.

Figure 3



INSTALLATION INSTRUCTIONS

Chart C: 2009 to 2012 Ram

Aftermarket display / Factory 6.1" display

Color	Polarity	Function	Location
Green	(+)	Reverse	Splice to white/red wire in Instrument Panel connector pin 7 (Figure 7)
Red	(+)	Ignition	Splice to pink/green wire in Instrument Panel connector pin 16 (Figure 7)
Black	(-)	Ground	Chassis ground (Figure 8)

Figure 4

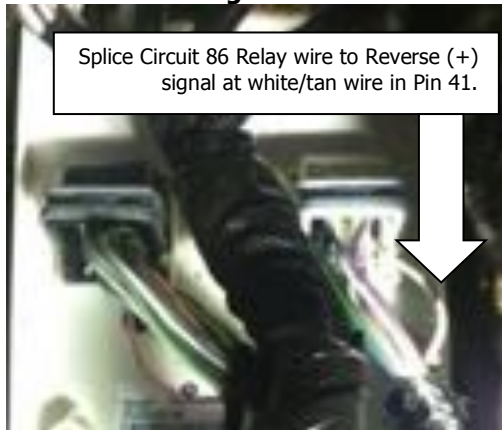

Figure 5

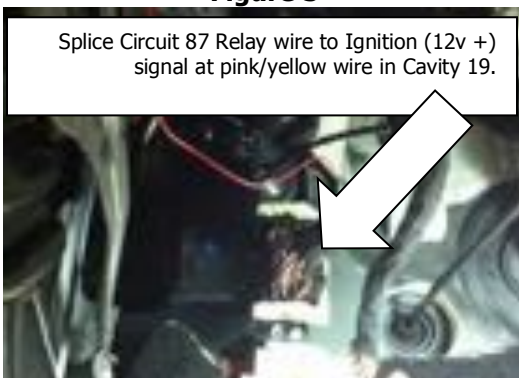
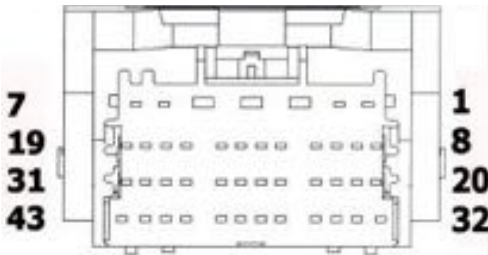

Figure 6

Connector I 310 F (black)



48. Plug the male Single Pull Dual Throw Relay connector into the female Relay connector and secure to existing vehicle wiring using a Wire Tie.

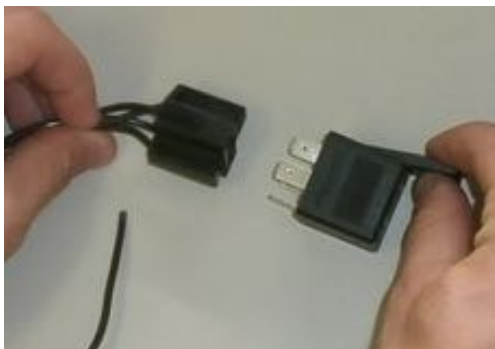

Figure 7

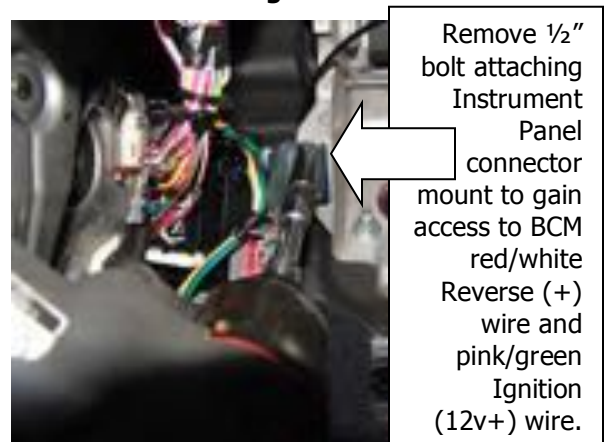
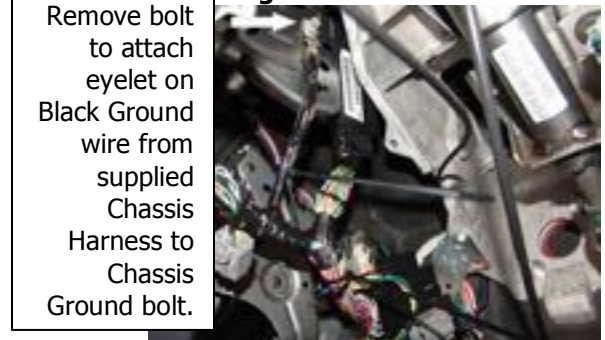

Figure 8



49. **If using this kit with the factory 8.4" touch screen 5.0", follow Steps 49 through 64 and Steps 67 through 69 below.**

If using this kit with an aftermarket mirror / display / 6.1" factory display, connect Chassis Harness male RCA to "Camera IN" on the aftermarket mirror / display/ NAV display. NOTE: A RCA extension may be required. Proceed to Step 61.

50. Use of this camera with the factory Ram 8.4" touch screen requires activation by a Chrysler/Dodge dealer. See below for Dealer Programming Instructions. If possible, have the dealer "enable" the camera option prior to installation.
51. Use a Plastic Trim Tool to remove shifter bezel and remove two screws from under the rubber mat using a Phillips screwdriver.
52. Use a Plastic Trim Tool to remove cup holder bezel.
53. Remove rubber mat on top of 8.4" screen to expose two screws and remove them using a T20 Torx bit.
54. Remove rubber mat in square cubby hole to expose one screw and remove it using a T20 Torx bit.
55. Use a Plastic Trim tool to remove radio bezel to expose the 4 screws securing the radio head unit and remove them using a 7mm socket.
56. Unplug all radio connectors from the radio head unit and set radio aside.
57. Connect supplied 8.4" Touch Screen Jumper Harness to RCA end of supplied Chassis Harness.



58. Locate pin position 31 on the black 52-pin radio connector and insert Red terminal of 8.4" Touch Screen Jumper Harness until it clicks securely.

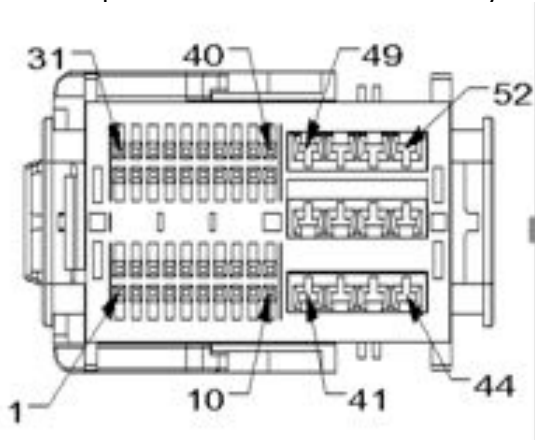

59. Insert Black terminal of 8.4" Touch Screen Jumper Harness into pin position 32 on the black 52-pin radio connector until it clicks securely.

Note: If the terminals, on the jumper harness, do not seat properly cut and splice loose wires provided in the small zip lock bag.

INSTALLATION INSTRUCTIONS

60. Reconnect all radio connectors and reinstall radio head unit and all trim removed in Steps 50-54. **(Skip to step number 65)**
61. Unplug all radio connectors from the radio head unit and set radio aside.
Note: If vehicle is NOT equipped with a 22-pin radio connector (Figure 3), use supplied white connector to complete steps 43 and 44.

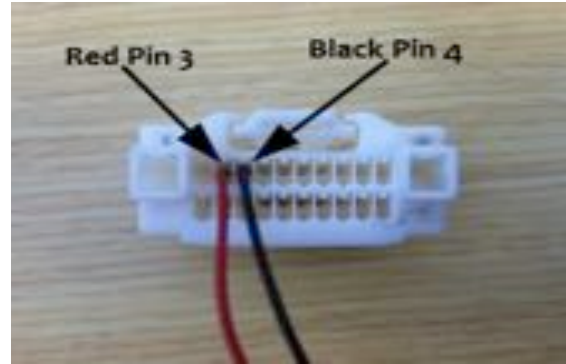

Figure 3

Pin 4 – Black terminal

Pin 3 – Red terminal

IMPORTANT: If the white 22-pin connector is present in the vehicle and pin 3 and/or pin 4 are already populated, remove the terminal(s) using Delphi terminal removal tool# 12094429 or a small flat watch repair screwdriver and isolate with electrical tape.

62. Locate pin position 3 on the white 22-pin radio connector (Figure 3) and insert red terminal of the jumper harness until it clicks securely.
63. Insert black terminal of the jumper harness into pin position on the white 22-pin radio connector (Figure 3) until it clicks securely.
64. Connect white 22-pin connector to radio along with all remaining connectors before reinstalling radio head unit and all trim removed.
65. Route Chassis Harness behind rear cab mount and out to the inside of the vehicle. **RECOMMENDED:** Use a Wire Tie to secure Chassis Harness between the cab and bed mount.



66. Continue to route supplied Chassis Harness next to the existing wiring harness along the inside edge of the frame rail. RECOMMENDED: Secure supplied Chassis Harness to the existing wiring harness with Wire Ties.
67. Once the Chassis Harness has been routed to the rear of the truck bed, coil and secure any excess length on the harness and tuck above the spare tire. Secure with Wire Ties (recommended) or Electrical Tape.
68. Plug Camera Harness connector into the Chassis Harness connector at the rear of the vehicle.
69. Start vehicle and shift into Reverse in order to check that all connections were made properly. If all of the connections are correct you will see the camera image displayed on your aftermarket mirror / display/ NAV display.
70. Reassemble all previously removed parts.
71. **If you connected the camera to a factory 8.4" touch screen, and the vehicle has not been reprogrammed to "enable" the camera, have a Chrysler/Dodge dealer program the vehicle as follows:**

Dealer Programming Instructions

PARK VIEW REAR BACK-UP CAMERA VEHICLE CONFIGURATION

Vehicle VIN must be updated with the sales code of the added accessory in order to enable system functionality. Using the DealerCONNECT website and the scan tool, complete the procedure below:

- A. Log on to <https://dealerconnect.chrysler.com>.
- B. In the "Vehicle Option" screen under "Global Claims System" category in the "Service" tab, enter the VIN and add the following sales code: XAC (PARK VIEW REAR BACK-UP CAMERA) as a "Dealer Installed Option."
- C. Confirm that the new sales code has been successfully added to the VIN. With the scan tool connected to both the internet (via Ethernet port or wireless connection) and the vehicle, follow the steps below:

INSTALLATION INSTRUCTIONS

- D. Using the scan tool select the VEHICLE PREPARATION and then select RESTORE VEHICLE CONFIGURATION.
- E. Follow the step by step instructions on the scan tool to complete the Park View Rear Back-Up Camera vehicle configuration.
72. Start vehicle and shift into Reverse in order to check that all connections were made properly. If all of the connections are correct you will see the camera image displayed on your factory 8.4" touch screen.
73. Reassemble all previously removed parts.